

**2000 No. 3215**

**DISABLED PERSONS  
TRANSPORT**

**The Rail Vehicle Accessibility (Amendment) Regulations  
2000**

*Made - - - - - 7th December 2000*

*Laid before Parliament 7th December 2000*

*Coming into force - - 31st December 2000*

The Secretary of State in exercise of the powers conferred on him by section 46(1), (2) and (5) of the Disability Discrimination Act 1995(a) and of all other powers enabling him in that behalf, having consulted the Disabled Persons Transport Advisory Committee and such other representative organisations as he thought fit in accordance with section 46(11) of the said Act, hereby makes the following Regulations:—

**Citation and commencement**

1. These Regulations may be cited as the Rail Vehicle Accessibility (Amendment) Regulations 2000 and shall come in to force on 31st December 2000.

**Interpretation**

2. In these Regulations “the 1998 Regulations” means the Rail Vehicle Accessibility Regulations 1998(b).

**Preliminary**

3. The 1998 Regulations shall be amended in accordance with the following provisions.

**Amendment of regulation 2 (interpretation)**

4. In regulation 2(1) of the 1998 Regulations:
- (a) the definition of “light maintenance depot” shall be omitted;
  - (b) for the words ““magnetic levitation” and “monorail”” there shall be substituted ““magnetic levitation”, “monorail” and “track-based with side guidance””; and
  - (c) after the end of the definition of “passenger saloon” there shall be inserted—  
““photocell device” means a device which operates using a combination of a beam of light, a transmitter and a receiver;”.

---

(a) 1995 c. 50.  
(b) S.I. 1998/2456.

### **Amendment of regulation 3 (application of regulations)**

5.—(1) In regulation 3(1) of the 1998 Regulations for the words “or magnetic levitation systems”, there shall be substituted “, magnetic levitation systems or systems which are track-based with side guidance”.

(2) In regulation 3(2) of the 1998 Regulation the words “either” and “or the day after its first visit to a light maintenance depot following such occurrence, whichever shall be the sooner” shall be omitted.

### **Amendment of regulation 4 (doors)**

6. In regulation 4(3)(b) of the 1998 Regulations the word “only” shall be omitted.

### **Amendment of regulation 5 (door controls)**

7.—(1) In regulation 5(1) of the 1998 Regulations, after the words “power-operated door”, there shall be inserted “, other than a device to which paragraph (3) below applies,”.

(2) In regulation 5(1)(b) of the 1998 Regulations for the word “pressure” there shall be substituted “force”.

(3) After Regulation 5(2) there shall be inserted the following paragraphs—

“(3) Subject to paragraph (4) below, no control device which opens a door automatically as a passenger approaches that door shall be fitted to a regulated rail vehicle unless:

- (a) the door starts to open before any part of a passenger reaches a distance of less than 500 millimetres, measured horizontally, from the vertical centre line of the door surface;
- (b) the door, once opened, remains open for a period of not less than 5 seconds before it closes; and
- (c) if, after the door starts to close, the edge of the door comes into contact with any part of a passenger the door opens again.

(4) If a control device, to which paragraph (3) above applies, incorporates a photocell device positioned above the door, the requirement imposed by paragraph (3)(a) above will be complied with if the distance from the vertical centre line of the door is measured horizontally from any single point on that line not more than 300 millimetres above the floor”.

### **Amendment of Regulation 9 (tramcar request-stop controls)**

8.—(1) In regulation 9(c) of the 1998 Regulations the word “a” shall be omitted on the first occasion on which it appears.

(2) In regulation 9(f) of the 1998 Regulations for the word “pressure” there shall be substituted “force”.

### **Amendment of Regulation 16 (wheelchair space specifications)**

9. In regulation 16(1)(f) of the 1998 Regulations for the words “marked on the fixed structure”, there shall be substituted “placed immediately next to, or in, the wheelchair space so as to identify the space as a wheelchair space”.

### **Amendment of Regulation 20 (toilets for disabled persons in wheelchairs)**

10. In regulation 20(1)(f)(ii) of the 1998 Regulations after the words “paragraph (2)” there shall be inserted “(a), (c), (d) and (e)”.

**New Regulation 20A (wheelchair access to on board facilities)**

**11.** After Regulation 20 of the 1998 Regulations there shall be inserted the following regulation—

“20A. There shall be no obstruction to prevent, or cause unreasonable difficulty to, a reference wheelchair being manoeuvred to, from, into or out of any wheelchair space, any toilet cubicle complying with Regulation 20 or any wheelchair-compatible sleeping compartment in that regulated rail vehicle.”

**Amendment of Schedule, Diagram A (reference wheelchair)**

**12.** For Diagram A in the Schedule to the 1998 Regulations there shall be substituted Diagram A in the Schedule to these Regulations.

Signed by authority of the Secretary of State  
for the Environment, Transport and the Regions.

*Keith Hill*  
Parliamentary Under-Secretary of State,  
Department of the Environment,  
Transport and the Regions

7th December 2000

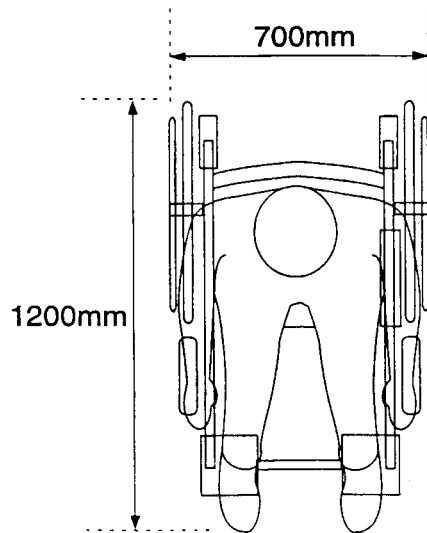
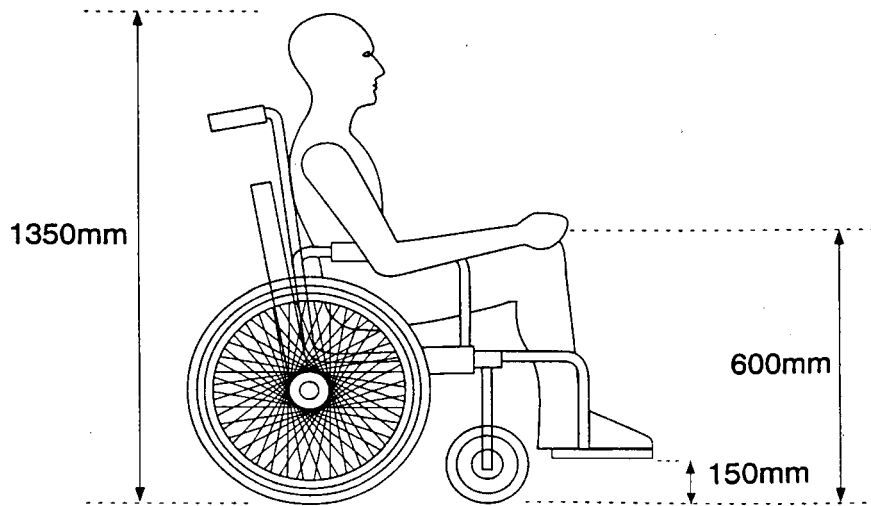

Diagram A - Reference Wheelchair

## EXPLANATORY NOTE

*(This note is not part of the Order)*

The Rail Vehicle Accessibility Regulations 1998 (“the 1998 Regulations”) came into force on 1st November 1998, and were made under the Disability Discrimination Act 1995. The 1998 Regulations require all passenger-carrying vehicles (known as “regulated rail vehicles”) used on railways, tramways, monorail systems or magnetic levitation systems, which are first brought into use, or belong to a class of vehicle first brought in to use, after 31st December 1998, to meet certain minimum requirements for the benefit of disabled people.

These Regulations amend the 1998 Regulations so that they also apply to an additional form of guided transport, namely systems which are track-based with side guidance. These Regulations also make the following amendments—

- to provide operators with 6 days in all circumstances to ensure compliance with the 1998 Regulations when a vehicle fails or becomes damaged;
- to allow additional audible warnings when some doors are closed;
- to allow automatic door opening and closing devices;
- to ensure wheelchair access to wheelchair spaces, toilets for wheelchair users and wheelchair-compatible sleeping compartments;
- to ensure that wheelchair spaces are clearly identified as wheelchair spaces;
- to disapply certain dimensional requirements from hinged handrails in disabled persons toilets.
- to replace one of the diagrams in the Schedule to the 1998 Regulations; and
- other minor changes designed to ensure consistency throughout the Regulations.

These Regulations have been notified to the European Commission and the other member States in accordance with Directive 98/34/EC of the European Parliament and of the Council (OJ No. L204, 21.7.98, p. 37), as amended by Directive 98/48/EC of the European Parliament and of the Council (OJ No. L217, 5.8.98, p. 18).





**2000 No. 3215**

**DISABLED PERSONS  
TRANSPORT**

**The Rail Vehicle Accessibility (Amendment) Regulations  
2000**

£2.00

© Crown copyright 2000

Printed and published in the UK by The Stationery Office Limited  
under the authority and superintendence of Carol Tullo, Controller of  
Her Majesty's Stationery Office and Queen's Printer of Acts of Parliament.  
E2248 12/2000 570334 19785

ISBN 0-11-018899-3



9 780110 188997